

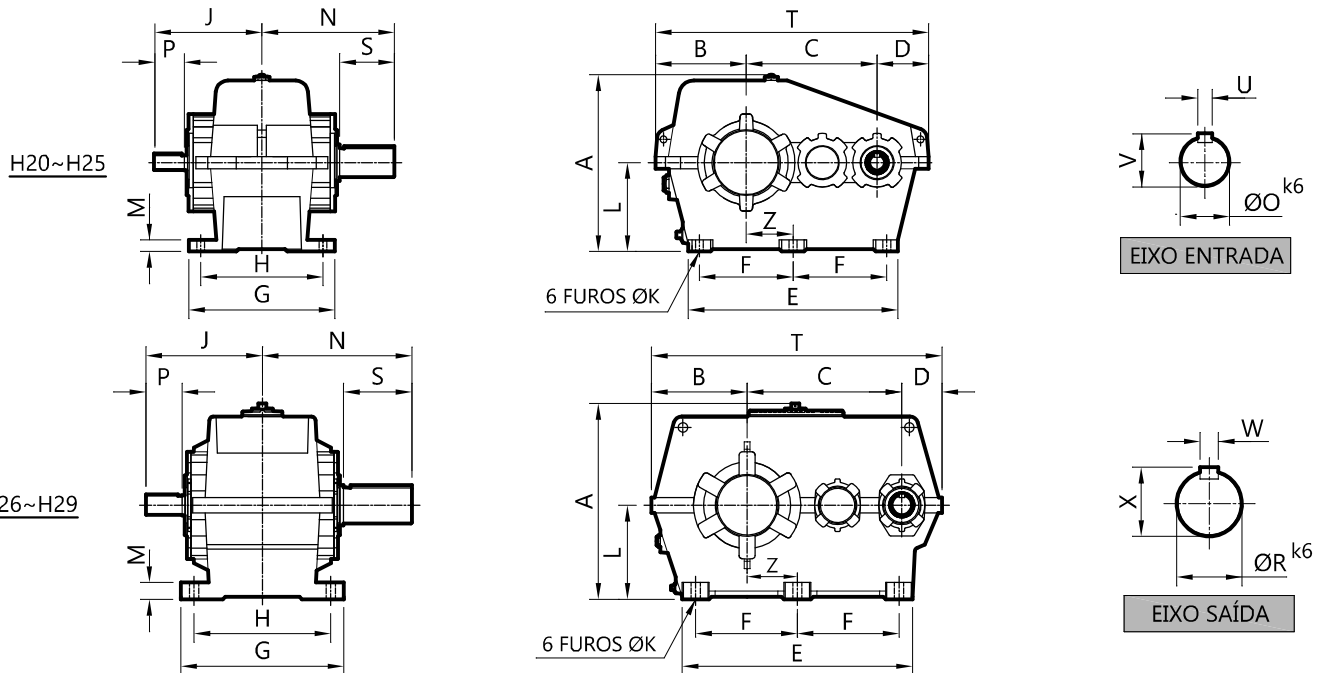

# REDUTORES A ENGRENAGENS HELICOIDAIS - LINHA H1000

## CAPACIDADES A 1750 RPM NA ENTRADA

TIPO	REDUÇÃO	6.3	7.1	8	9	10	11,2	12,5	14	16	18	20	22,4	25
H20	POTÊNCIA (CV)	18.1	15.7	13.6	11.9	10.5	9.1	8.0	7.0	6.0	5.2	4.6	4.0	3.5
	RED. EFETIVA	6.3	7.0	8.1	9.1	9.9	11.2	12.7	13.8	15.8	18.2	19.8	23.7	25.7
	TORQUE (Kgfm)	45	43	43	42	41	40	40	38	37	37	36	37	35
H21	POTÊNCIA (CV)	42.4	35.8	30.2	25.5	22.0	18.7	16.0	13.6	11.2	9.5	8.2	7.0	6.0
	RED. EFETIVA	6.5	7.0	7.8	8.8	10.1	11.4	12.8	13.9	16.0	18.4	20.0	23.0	25.0
	TORQUE (Kgfm)	108	98	92	88	87	83	80	74	70	68	64.0	63	58
H22	POTÊNCIA (CV)	72.0	60.4	50.6	42.5	36.4	30.7	26.1	22.1	18.1	15.2	13.0	11.0	9.4
	RED. EFETIVA	6.4	7.1	7.9	9.1	10.2	11.8	12.5	14.1	16.2	18.4	20.0	22.9	25.0
	TORQUE (Kgfm)	180	167	156	151	145	141	127	122	114	109	101	98	92
H23	POTÊNCIA (CV)	114.0	95.6	80.1	67.3	57.6	48.8	41.5	35.1	28.8	24.2	20.7	17.5	14.9
	RED. EFETIVA	6.3	7.1	8.0	8.6	10.5	11.3	12.7	13.7	15.6	17.9	20.3	22.4	25.4
	TORQUE (Kgfm)	280	265	250	226	236	215	206	188	175	169	164	153	148
H24	POTÊNCIA (CV)	172.4	145.6	122.7	103.2	89.7	76.1	64.8	55.0	45.2	38.1	32.7	27.7	23.6
	RED. EFETIVA	6.2	7.1	8.0	8.9	10.6	11.9	12.6	14.0	16.1	18.2	21.2	22.1	25.7
	TORQUE (Kgfm)	420	406	385	361	371	353	318	300	286	270	270	239	236
H25	POTÊNCIA (CV)	247.6	212.6	182.6	155.2	132.3	112.6	99.1	84.2	69.5	58.7	50.5	42.9	36.6
	RED. EFETIVA	6.2	7.1	8.0	8.9	10.5	11.7	12.4	13.8	15.8	18.0	19.6	21.5	23.4
	TORQUE (Kgfm)	603	593	573	543	545	517	479	453	428	412	386	360	334
H26	POTÊNCIA (CV)	347.6	298.7	257.8	222.3	196.1	170.3	147.2	125.3	103.7	87.7	75.6	64.3	55.1
	RED. EFETIVA	5.7	6.9	7.5	8.4	10.3	11.5	13.0	14.9	17.1	18.4	21.4	22.2	25.8
	TORQUE (Kgfm)	778	809	759	733	793	769	746	728	691	629	631	557	554
H27	POTÊNCIA (CV)	466.7	406.4	352.8	305.7	273.6	240.1	209.8	180.7	149.7	126.9	109.4	93.3	79.9
	RED. EFETIVA	6.1	7.2	8.1	9.2	10.0	11.3	12.2	14.0	16.0	17.6	19.4	22.3	24.6
	TORQUE (Kgfm)	1118	1150	1122	1104	1074	1065	1005	987	934	871	828	811	767
H28	POTÊNCIA (CV)	607.5	537.3	472.3	411.1	367.7	325.7	290.3	250.3	209.7	177.9	153.5	131.0	112.4
	RED. EFETIVA	6.2	7.2	8.1	9.2	10.9	12.4	13.4	15.2	17.2	19.3	21.0	23.0	25.0
	TORQUE (Kgfm)	1479	1520	1503	1485	1574	1586	1528	1494	1439	1338	1257	1175	1096
H29	POTÊNCIA (CV)	805.4	707.0	616.5	541.5	486.5	427.6	382.5	333.2	288.1	244.7	211.5	—	155.3
	RED. EFETIVA	6.2	7.1	7.6	8.3	10.4	11.4	12.9	14.1	16.3	17.8	21.4	—	25.8
	TORQUE (Kgfm)	1961	1972	1840	1765	1987	1915	1938	1840	1831	1699	1765	—	1560



TIPO	A	B	C	D	E	F	G	H	J	ØK	L	M	N	ØO	P	ØR	S	T	U	V	W	X	Z	PESO
H20	215	122	171	72	313	115	174	150	135	13	102	16	163	18	40	38	65	365	6	20,5	10	41	65	48
H21	260	130	192	63	310	139	217	180	165	13	130	19	198	22	45	42	80	385	6	24,5	12	45	69,5	51
H22	291	149	215	85	353	154	240	201	176	13	146	23	218	24	50	48	90	449	8	27,0	14	51,5	77	68
H23	324	166	240	84	387	170	257	222	185	13	160	30	235	28	50	55	100	490	8	31,0	16	59	80	79
H24	352	188	272	87	435	189	284	238	215	17	185	30	268	32	65	65	120	547	10	35,0	18	69	106	104
H25	390	215	305	110	480	212	305	267	235	17	200	30	305	38	70	75	140	630	10	41,0	20	79,5	109	137
H26	427	225	340	95	515	230	340	275	258	17	205	40	332	42	80	80	155	660	12	45,0	22	85	125	201
H27	481	243	385	100	573	253	405	345	290	23	234	42	372	48	90	90	170	728	14	51,5	25	95	125	261
H28	517	272	430	105	637	285	415	364	340	23	250	45	421	50	120	100	200	807	14	53,5	28	106	137	342
H29	597	298	480	125	723	320	471	405	374	26	293	45	465	60	130	110	220	903	18	64,0	28	116	152	458

### FATOR DE VELOCIDADE FV ( POT. EQUIVALENTE = POT. TABELA x FV )

rpm	1500	1200	900	600	300	100
FV	0.87	0.71	0.60	0.43	0.20	0.10



# REDUTORES A ENGRENAGENS HELICOIDAIS - LINHA H1000

## FLANGE PARA MOTORES

FORMAS 1 A 9

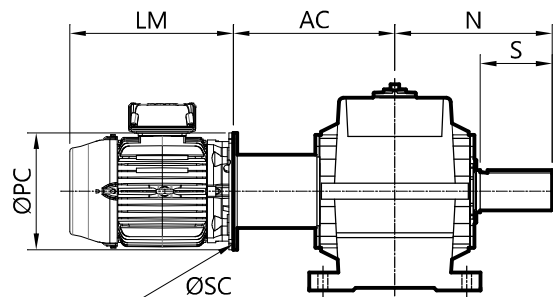

FORMAS 10 E 12

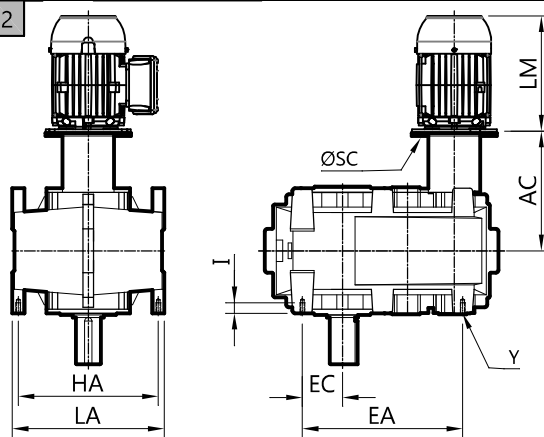

REDUTOR TIPO	MOTOR		FLANGE "F"				FORMAS 10 E 12					
	CARÇAÇA	LM	TIPO	AC	PC	SC	EA	EC	HA	I	LA	Y
H20	80	262	F165-20	212.5	200	12	281	75,5	176	28	204	M12
	90	309.5	F165-20	212.5	200	12						
	100/112	369	F215-20	238	250	15						
	132*	434.5	F265-20	258.5	300	15						
H21	80	262	F165-21	240	200	12	278	69,5	242	25	260	M10
	90	309.5	F165-21	240	200	12						
	100/112	369	F215-21	262.5	250	15						
	132*	434.5	F265-21	274.5	300	15						
H22	90	309.5	F165-22	253.5	200	12	308	77	267	30	292	M12
	100/112	369	F215-22	275	250	15						
	132*	434.5	F265-22	285.5	300	15						
H23	100/112	369	F215-23	271	250	15	340	90	290	30	320	M12
	132	434.5	F265-23	293	300	15						
	160*	534.5	F300-23	346.5	350	19						
	180*	554	F300-23	346.5	350	19						
H24	100/112	369	F215-24	295	250	15	378	83	340	32	370	M16
	132	434.5	F265-24	319	300	15						
	160	534.5	F300-24	370	350	19						
	180*	554	F300-24	370	350	19						
H25	100/112	369	F215-25	322.5	250	15	424	103	370	32	400	M16
	132	434.5	F265-25	344.5	300	15						
	160	534.5	F300-25	383.5	350	19						
	180	554	F300-25	383.5	350	19						
H26	132	434.5	F265-26	369.5	300	15	460	105	372	32	410	M16
	160	534.5	F300-26	408.5	350	19						
	180	554	F300-26	408.5	350	19						
	200*	656	F350-26	408.5	400	19						
H27	132	434.5	F265-27	407.5	300	15	506	128	424	45	468	M22
	160	534.5	F300-27	438	350	19						
	180	554	F300-27	438	350	19						
	200*	656	F350-27	438	400	19						
	225*	747	F400-27	437.5	450	19						
H28	160	534	F300-28	487	350	19	570	148	456	45	500	M22
	180	554	F300-28	487	350	19						
	200*	656	F350-28	485	400	19						
	225*	747	F400-28	490	450	19						
H29	160	534.5	F300-29	520	350	19	640	168	542	45	586	M22
	180	554	F300-29	520	350	19						
	200*	656	F350-29	521.5	400	19						
	225*	747	F400-29	530.5	450	19						

### FORMAS CONSTRUTIVAS

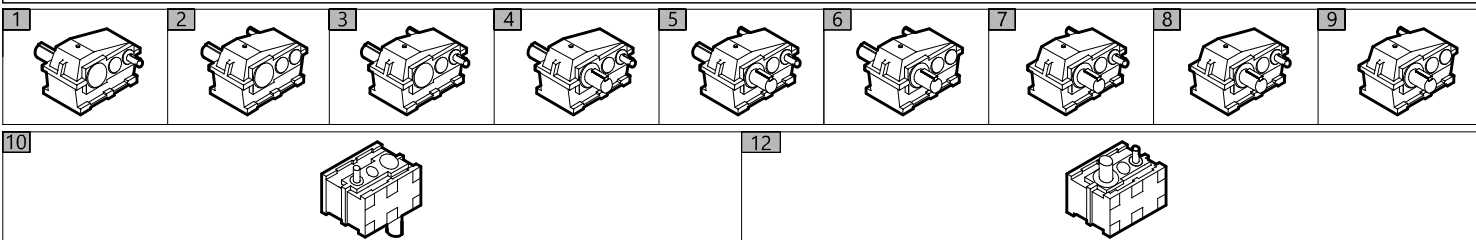

\*SOMENTE NAS FORMAS CONSTRUTIVAS 10 E 12  
OBS: INFORMAÇÕES SUJEITAS A ALTERAÇÕES SEM AVISO PRÉVIO